

COMPRESSOR

Displacement (cm ³)	9.09
Diameter (mm)	24.29
Stroke (mm)	19.62
Net Weight (Kg)	11.3
Oil type	ISO VG 46 ESTER
Oil charge (cm ³)	400

MOTOR

Approximate Power (CV)	3/8
Voltage/Frequency (V/Hz)	220V 50Hz
Voltage range (V)	187-264
Code	63.140
Type	CSIR
Phase number	1 PH
Locked rotor current (A)	16.0
Main W. resist. at 25°C (Ω)	4.68
Start W. resist. at 25°C (Ω)	10.5

APPLICATION

Application	High/Mid. back pressure
Refrigerant	R404A
Evaporating (°C)	-25 to 10
Expansion	Capillar/Valve
Comp. cooling	Fan cooled
Max. ambient temp. (°C)	43

NOMINAL PERFORMANCE	CYCLE C	CYCLE D
Cooling capacity (kcal/h)	973	1220
Input power (W)	647	665
EER (kcal/Wh)	1.50	1.83
COP (W/W)	1.75	2.13
Current (A)	3.71	3.79

TEST CONDITIONS

Evaporating temp. (°C)	5.0	7.2
Condensing temp. (°C)	55.0	55.0
Liq.t. entering expan. (°C)	55.0	46.0
Ambient t. and return (°C)	32.0	35.0
Tens/Freq (V/Hz)	220V 50Hz	220V 50Hz

ELECTRICAL COMPONENTS

Relay	2014 149.	
Pick-Up (A)	7,80	
Drop-Out (A)	6,65	
Protector	MRA38130	T0252/G.
Current (A)	11.7	11.5
Time check (seg)	7.5-14	7.5-14
Disc temp. (Open/Close) (°C)	105.0 / 52.0	105.0 / 52.0
Starting capacitor (μF/V)/F/V)	64- 77 / 330	

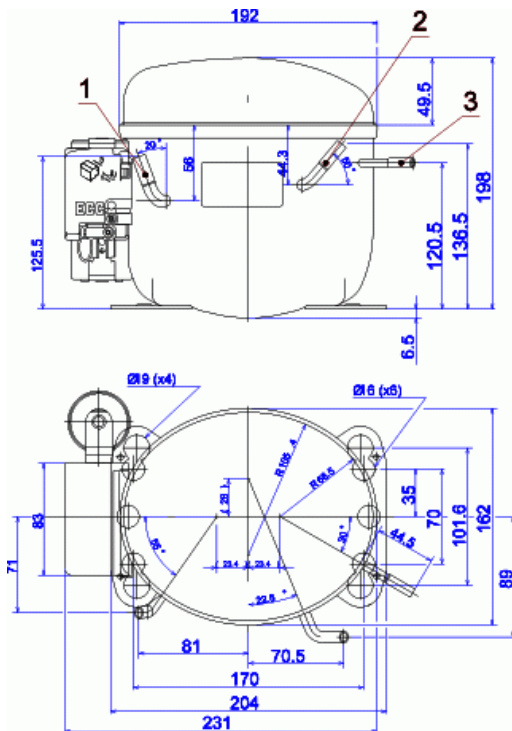
DIMENSIONS AND ELECTRICAL DIAGRAM

DESIGNATION	INTERNAL DIAM. (MM)
1 Suction	6.5
2 Service	6.5
3 Discharge	4.9

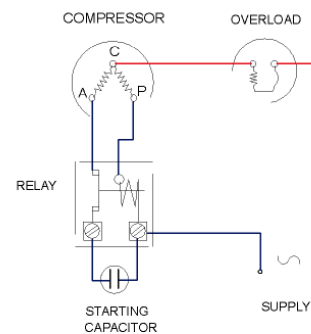
CSIR

TEST CONDITIONS

Voltage/frequency	220V 50Hz
Ambient t. and return	35 °C
Liq.t. entering expan.	Subcooling 9 K

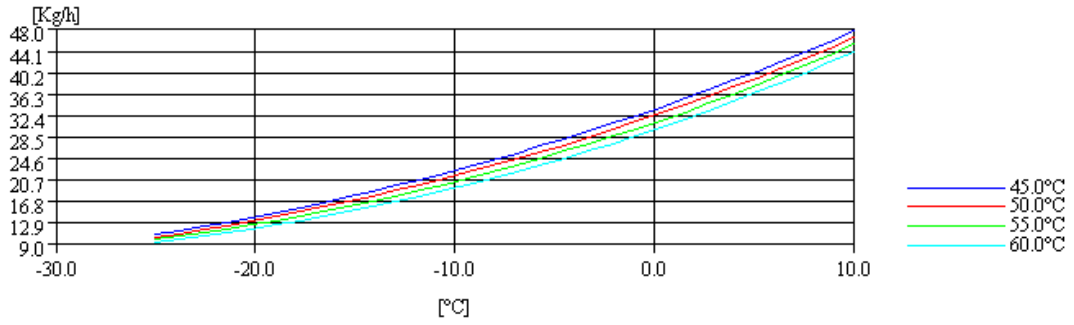
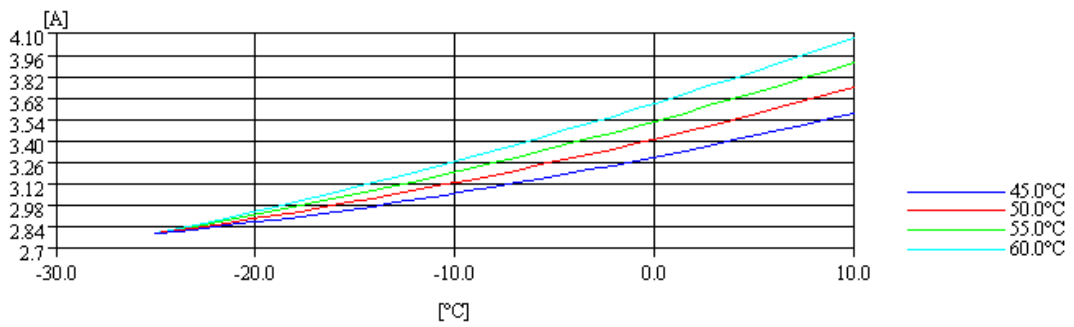
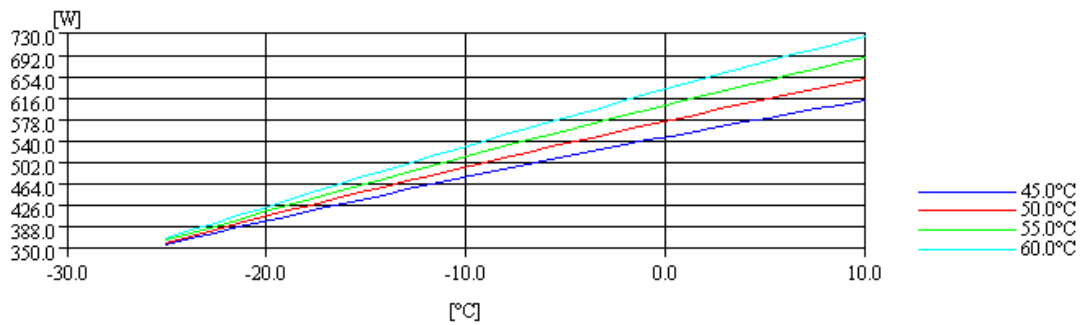
MASS FLOW

INTENSITY

CONSUMPTION

COOLING CAPACITY
